

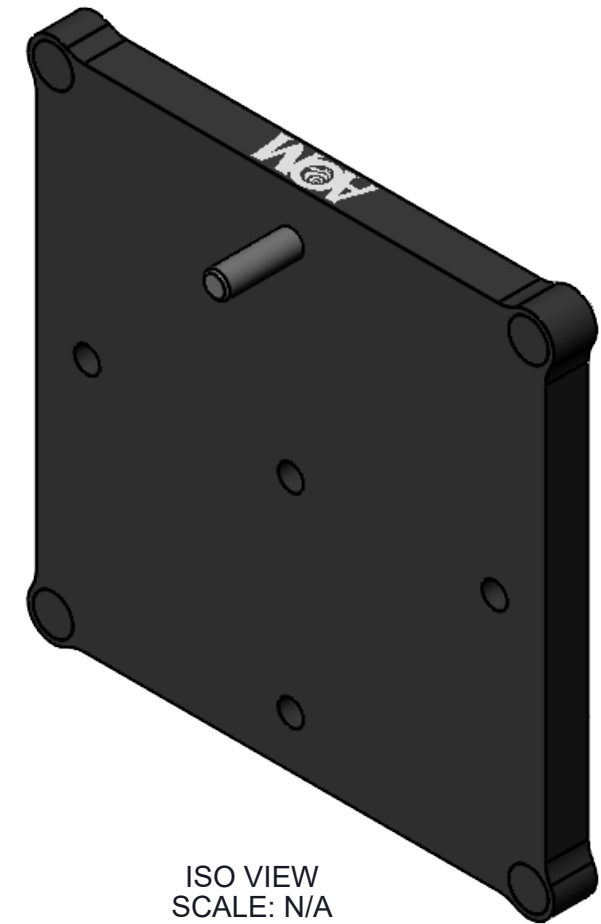

NOTES, UNLESS OTHERWISE SPECIFIED:
 1. FOR REFERENCE ONLY.

REV.	DESCRIPTION	DATE	APPROVED
A	INITIAL RELEASE	8/16/2023	C. MERLE

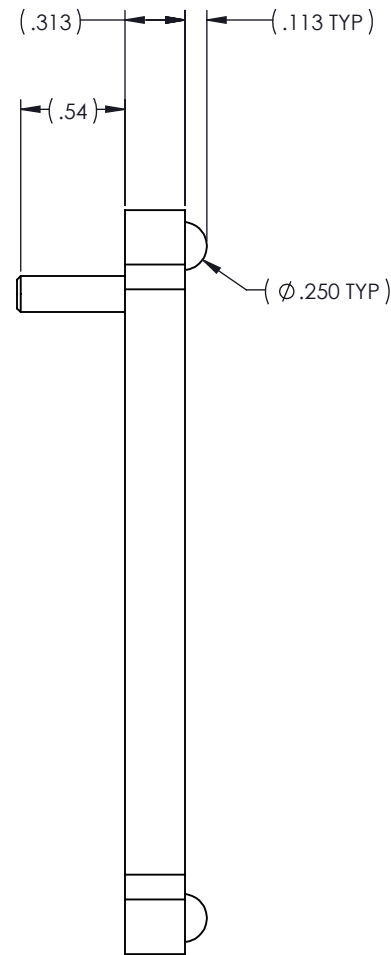
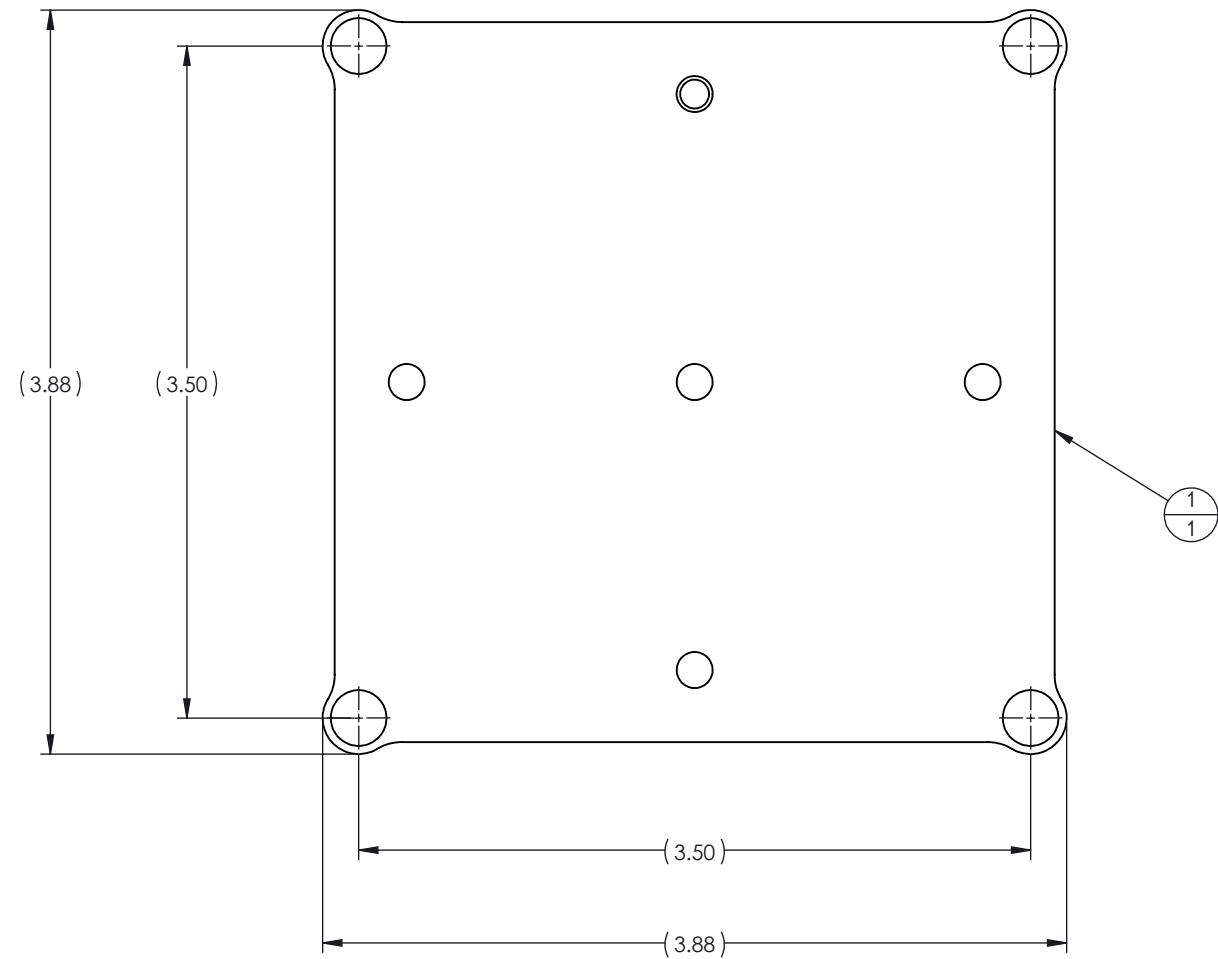

ITEM NO.	QTY.	PART NUMBER	DESCRIPTION
1	1	20-00008-00	ASSY, MP, 3 1/2 X 1/4

THIS DOCUMENT CONTAINS INFORMATION WHICH IS PROPRIETARY TO ARIZONA OPTICAL METROLOGY. NO REPRODUCTION OR PUBLICATION OF THIS DOCUMENT, IN WHOLE OR IN PART, SHALL BE MADE WITHOUT WRITTEN AUTHORIZATION FROM ARIZONA OPTICAL METROLOGY.	TOLERANCES			 ARIZONA OPTICAL METROLOGY 2420 W Ruthrauff Rd #160 TUCSON, AZ 85705 Phone: 520-833-5761 Email: info@CGHnulls.com	
	PLACES IN DIMENSION	.X	.XX		.XXX
	DIMENSIONS	±.05	±.01		±.005
	ANGLES	±.5°			
	FRACTIONS	±1/32			
	MATERIAL: N/A			TITLE	
UNLESS OTHERWISE SPECIFIED: ALL DIMENSIONS ARE IN INCHES AND APPLY AFTER COATING/PLATING.	HEAT TREAT: N/A			PLATFORM, METROLOGY, BLANK, MP3	
	FINISH: N/A				
DRAWING STANDARD PER: ASME Y14.5-2009 INTERPRET WELDING SYMBOLS PER AWS A2.4	DESIGN BY:	DATE:		SIZE	
	A. SCHAFFER	8/4/2023		B	
REMOVE ALL BURRS AND EDGE BREAK .01" MAXIMUM	DRAWN BY:	DATE:		DWG NO.	
	A. SCHAFFER	8/4/2023		MP3-BLANK	
	CHECKED BY:	DATE:		REV.	
	T. GROSS	8/16/2023		A	
DO NOT SCALE DRAWING	SCALE	1:1	WEIGHT	0.44 LBS	
			SHEET	1 OF 1	