

NOTES:

- 1. RETRO PATTERN REGION USED TO ALIGN CGH TO INTERFEROMETER.
- 2. NULL PATTERN REGION USED TO MEASURE TEST OPTIC.
- 3. ORIENT CGH PATTERNED SIDE AWAY FROM INTERFEROMETER.
- 4. CYLINDER LINE FOCUS PARALLEL TO CELL EDGE MARKED WITH AOM LOGO.

REV.	DESCRIPTION	DATE	APPROVED
A	INITIAL RELEASE	9/20/2023	A. CLARK

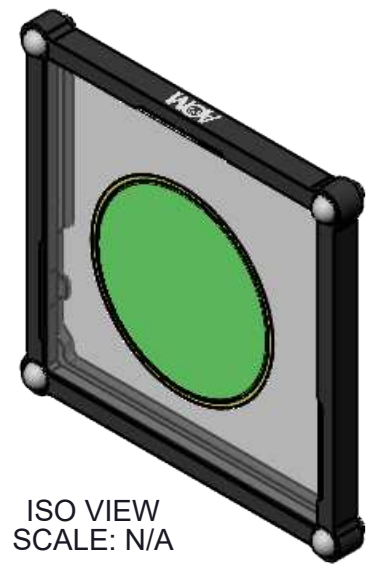
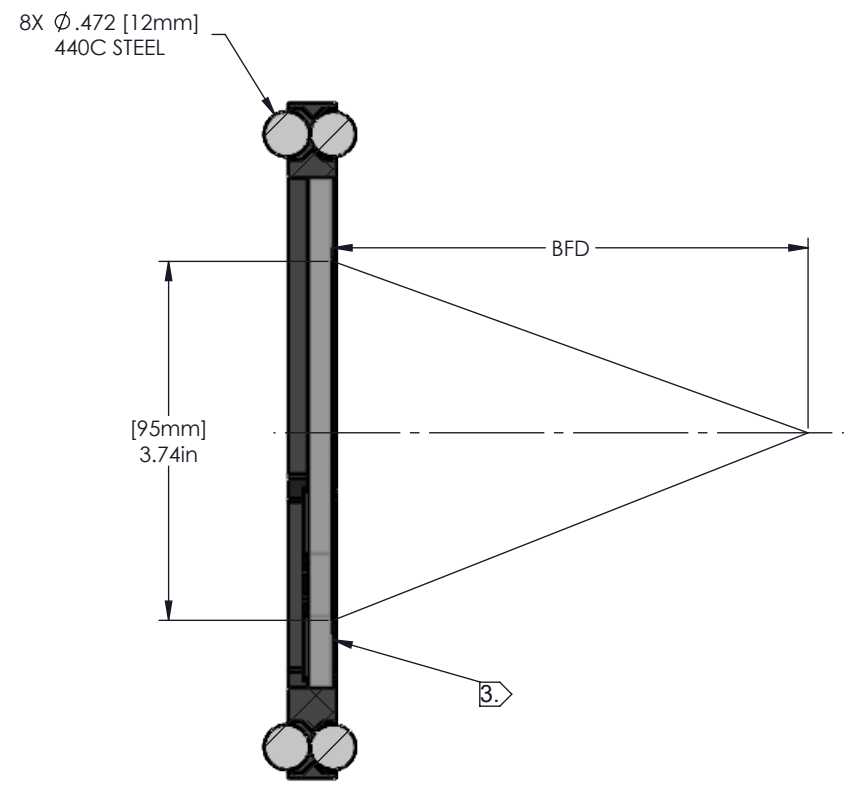
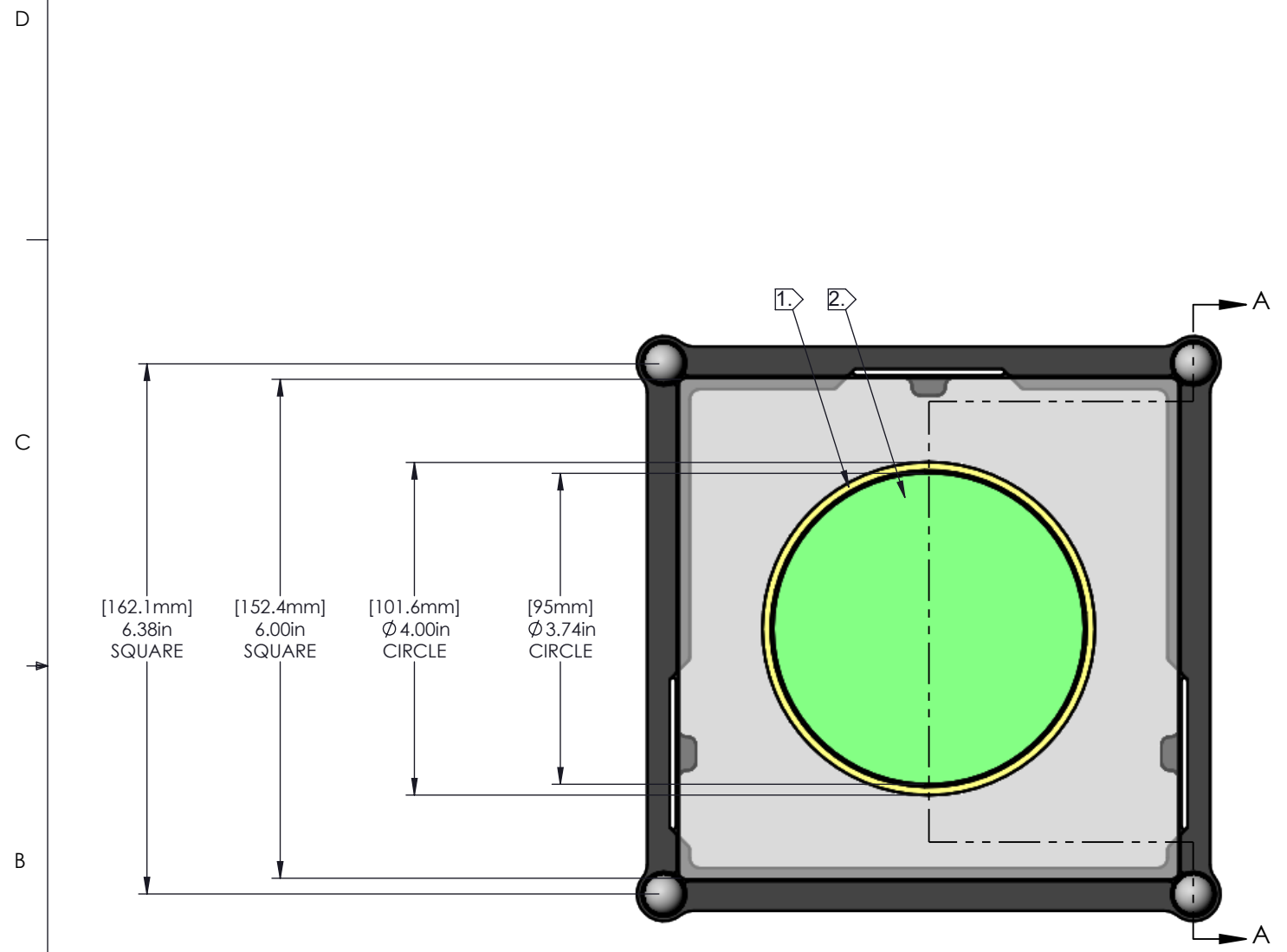

SECTION A-A

PART NUMBER	F#	BFD
C4075C	0.75	53.1 mm
C4090C	0.9	71.1 mm
C4100C	1.0	82.3 mm
C4150C	1.5	134.4 mm
C4160C	1.6	144.4 mm
C4200C	2.0	184.0 mm
C4300C	3.0	281.0 mm
C4400C	4.0	377.0 mm
C4500C	5.0	472.6 mm
C4550C	5.5	520.3 mm
C4600C	6.0	568.0 mm

THIS DOCUMENT CONTAINS INFORMATION WHICH IS PROPRIETARY TO ARIZONA OPTICAL METROLOGY. NO REPRODUCTION OR PUBLICATION OF THIS DOCUMENT, IN WHOLE OR IN PART, SHALL BE MADE WITHOUT WRITTEN AUTHORIZATION FROM ARIZONA OPTICAL METROLOGY.	TOLERANCES			 ARIZONA OPTICAL METROLOGY 2420 W Ruthrauff Rd #160 TUCSON, AZ 85705 Phone: 520-833-5761 Email: info@CGHnulls.com	
	PLACES IN DIMENSION	.X	.XX		.XXX
	DIMENSIONS	±.05	±.01		±.005
	ANGLES	±.5°			
	FRACTIONS	±1/32			
UNLESS OTHERWISE SPECIFIED: ALL DIMENSIONS ARE IN INCHES AND APPLY AFTER COATING/PLATING.	MATERIAL: N/A			TITLE CYLINDER CGH, F#, 95 mm CIRCULAR	
DRAWING STANDARD PER: ASME Y14.5-2009 INTERPRET WELDING SYMBOLS PER AWS A2.4	HEAT TREAT: N/A				
REMOVE ALL BURRS AND EDGE BREAK .01" MAXIMUM	FINISH: N/A			SIZE B DWG NO. C4XXXC REV. A	
DO NOT SCALE DRAWING	DESIGN BY: T. GROSS	DATE: 8/29/2023	SCALE 1:2 WEIGHT 1.85 LBS SHEET 1 OF 1		
	DRAWN BY: T. GROSS	DATE: 8/29/2023			
	CHECKED BY: T. STEELE	DATE: 9/20/2023			