

NOTES:

- 1. RETRO PATTERN REGION USED TO ALIGN CGH TO INTERFEROMETER.
- 2. NULL PATTERN REGION USED TO MEASURE TEST OPTIC.
- 3. ORIENT CGH PATTERNED SIDE AWAY FROM INTERFEROMETER.
- 4. CYLINDER LINE FOCUS PARALLEL TO CELL EDGE MARKED WITH AOM LOGO.

REV.	DESCRIPTION	DATE	APPROVED
A	INITIAL RELEASE	9/20/2023	A. CLARK

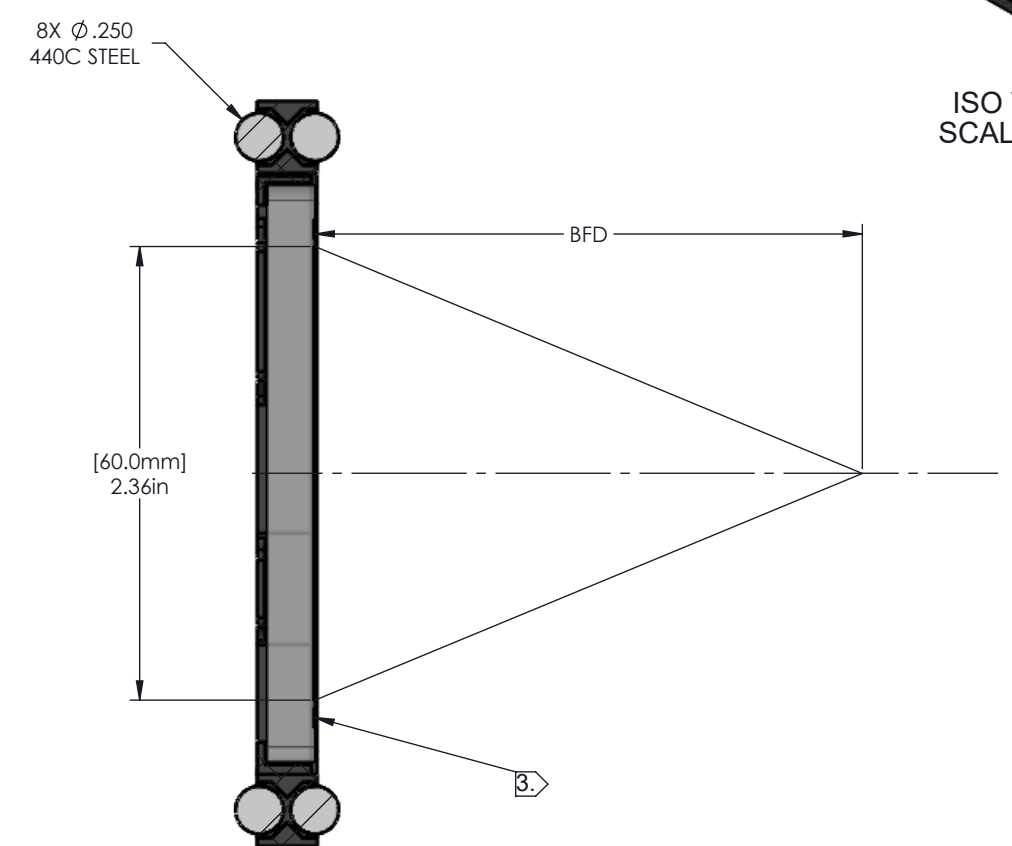
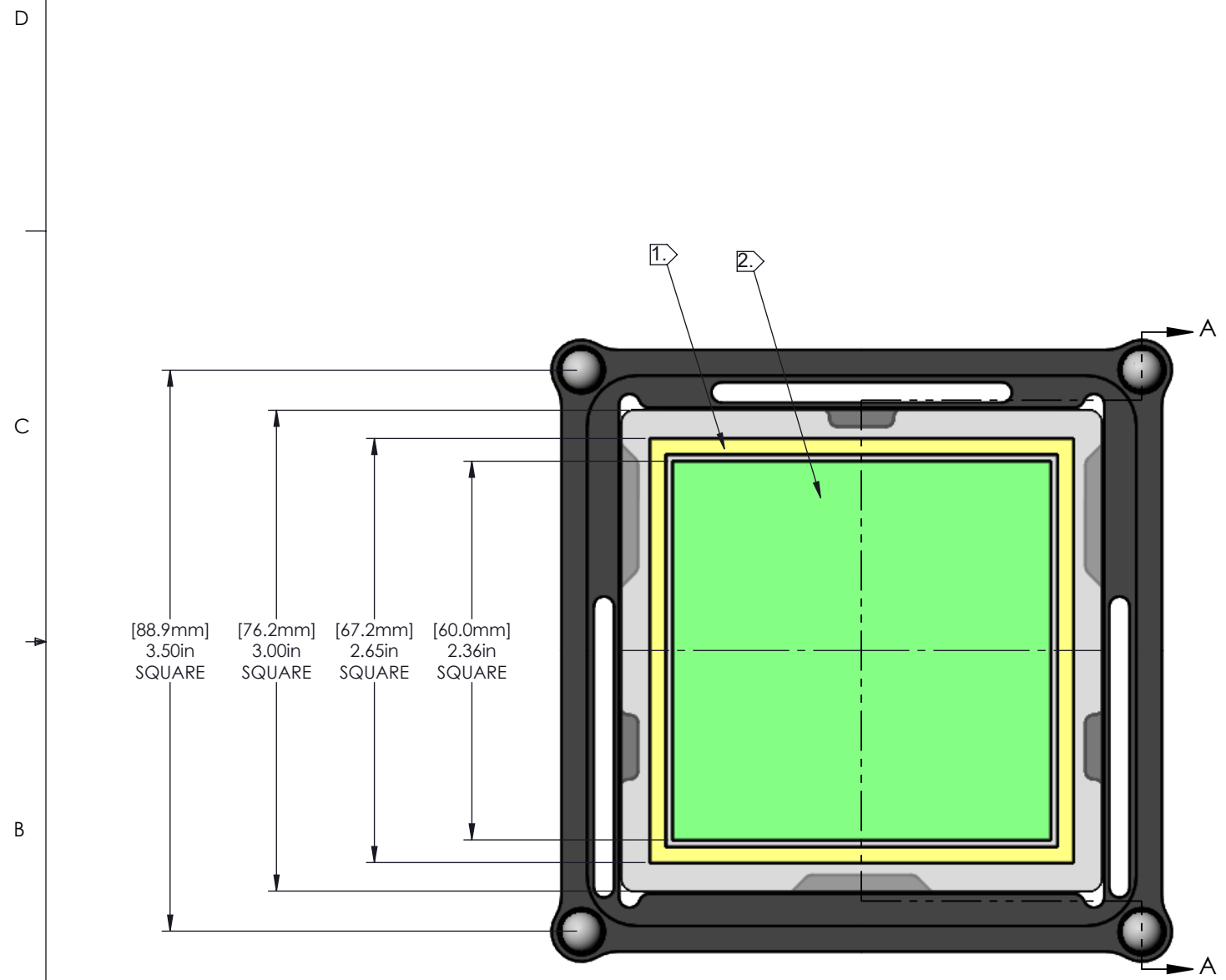

SECTION A-A

PART NUMBER	F/#	BFD
C3070S	0.7	29.4 mm
C3090S	0.9	44.9 mm
C3100S	1.0	52.0 mm
C3150S	1.5	84.9 mm
C3200S	2.0	116.2 mm
C3300S	3.0	177.5 mm
C3400S	4.0	238.1 mm
C3500S	5.0	298.5 mm
C3600S	6.0	358.7 mm

THIS DOCUMENT CONTAINS INFORMATION WHICH IS PROPRIETARY TO ARIZONA OPTICAL METROLOGY. NO REPRODUCTION OR PUBLICATION OF THIS DOCUMENT, IN WHOLE OR IN PART, SHALL BE MADE WITHOUT WRITTEN AUTHORIZATION FROM ARIZONA OPTICAL METROLOGY.	TOLERANCES			 ARIZONA OPTICAL METROLOGY 2420 W Ruthrauff Rd #160 TUCSON, AZ 85705 Phone: 520-833-5761 Email: info@CGHnulls.com	
	PLACES IN DIMENSION	.X	.XX		.XXX
	DIMENSIONS	±.05	±.01		±.005
	ANGLES	±.5°			
REMOVE ALL BURRS AND EDGE BREAK .01" MAXIMUM	FRACTIONS			±1/32	
UNLESS OTHERWISE SPECIFIED: ALL DIMENSIONS ARE IN INCHES AND APPLY AFTER COATING/PLATING.	MATERIAL: N/A			TITLE CYLINDER CGH, F/#, 60 mm SQUARE	
DRAWING STANDARD PER: ASME Y14.5-2009 INTERPRET WELDING SYMBOLS PER AWS A2.4	HEAT TREAT: N/A				
	FINISH: N/A			SIZE B	
	DESIGN BY: T. GROSS	DATE: 8/29/2023	DWG NO. C3XXXS		
	DRAWN BY: T. GROSS	DATE: 8/29/2023	REV. A		
	CHECKED BY: T. STEELE	DATE: 9/20/2023	SCALE 1:1	WEIGHT 0.38 LBS	
DO NOT SCALE DRAWING	SHEET			1 OF 1	