

The 9-inch computer-generated hologram (CGH) from AOM enables precision snapshot metrology of up to 7" diameter convex optics. The large-format CGH includes a complete set of optical and mechanical features that provide ease of use, precision, and simple procurement for complex surface metrology applications.

Features

- ▶ 9" x 9" x ¼" fused silica substrate (S9) providing large area metrology
- ▶ 200 mm max null pattern size for up to 175 mm diameter convex optical surface metrology
- ▶ Amplitude or Phase grating available for high- or low-reflectivity surfaces
- ▶ Collimated or spherical input beam for flexible configuration and interferometer aperture
- ▶ AR coated back surface to reduce unwanted reflections and noise in measurements
- ▶ < 10 nm RMS wavefront error contribution (typical)
- ▶ Permanently bonded mechanical cell (C9) using a 3-point flexure mount to minimize distortion and provide safe, easy handling
- ▶ Multiple safety features for investment protection
- ▶ Kinematic mounting balls on all edges for repeatable and stable mounting to alignment stage in any orientation

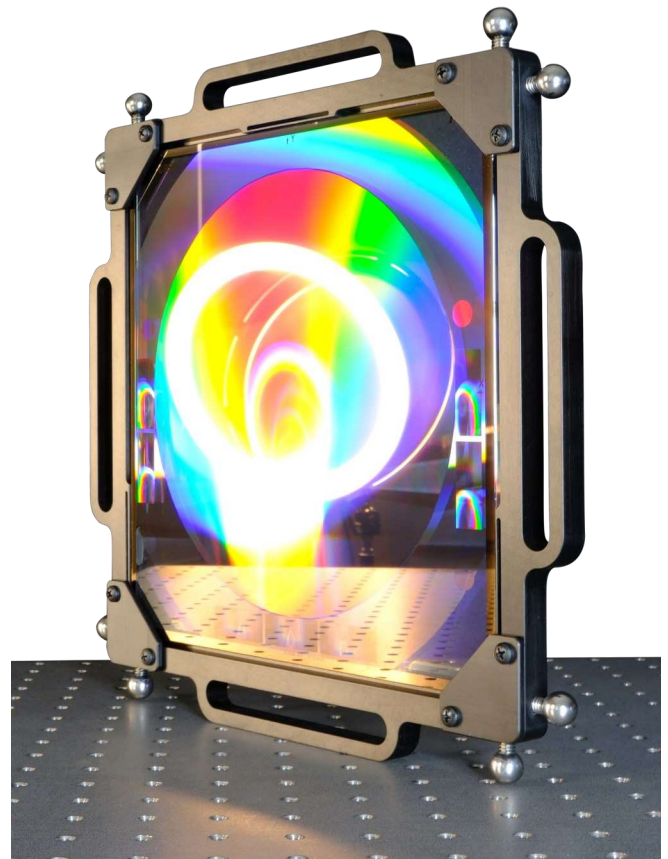

9-inch CGH assembly: 9-inch substrate (S9) mounted in C9 mechanical cell. Compatible with FP9 alignment stage (not pictured).

C9 Mechanical Cell

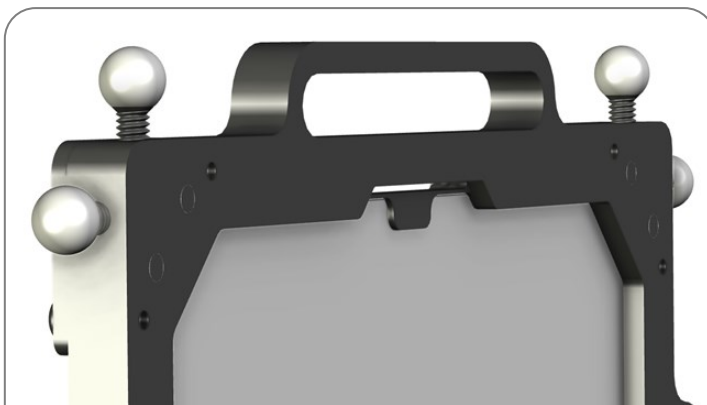

3-point flexure mounted substrate minimizes distortion. Integrated handles provide ease of handling. Kinematic mounting balls on all 4 edges provide stable and repeatable mounting in any orientation

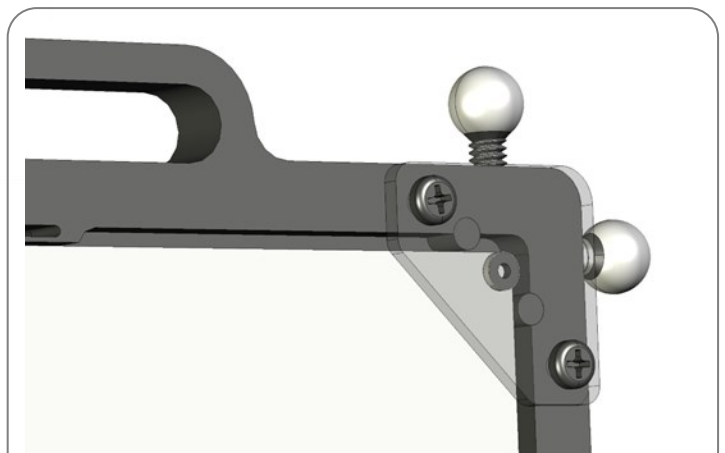

Corner bumpers and restraints protect the S9 substrate from minor drops and impacts

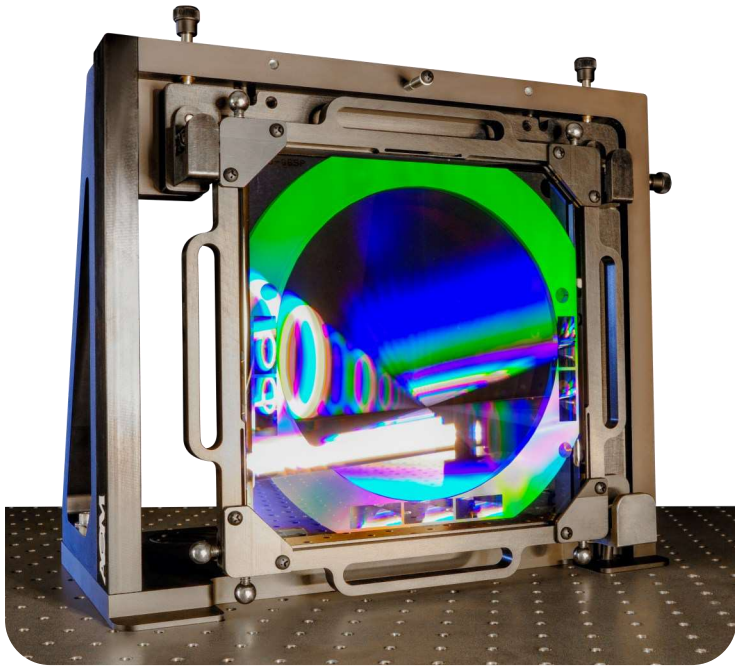

FP9 Alignment Stage

The purpose-built FP9 alignment stage provides a kinematic interface that accepts an AOM 9-inch CGH cell assembly in any orientation. Other key features include:

- ▶ 6 degree-of-freedom adjustment: +/- 4 mm range with sub-micron resolution in all 6 DOF
- ▶ 6.0" centerline height
- ▶ Infinitely adjustable mounting pucks to securely attach the FP9 in any setup
- ▶ Safety features to ensure a CGH stays connected even with forceful impact

9-inch CGH assembly mounted to FP9 alignment stage



7-inch Convex Asphere Metrology Demonstration Metrology System

Large convex optics test set measures a 7-inch diameter convex asphere using a 9-inch CGH and 3-inch holographic diverger to provide a full surface null test.

Large aperture interferometer not required!

